

### TECHINAL DETAILS

<b>Model</b>	<b>SC110 Cone Base Unit</b>
<b>Capacity</b>	<b>40-210tph</b>
CSS	5mm – 45mm
Max feed size	190mm
Installed power	110kW
Max lift	1950kg

### DIMENSIONS

Weight	12500kgs approx.
Length	2260mm
Width	18480mm
Height	2390mm

Note- Weight includes basic crusher and motor with anchoring fixings, v-belts for drive, control cabinet, motor support, lubrication station with hosing, fixing items, with easy transportation stack.

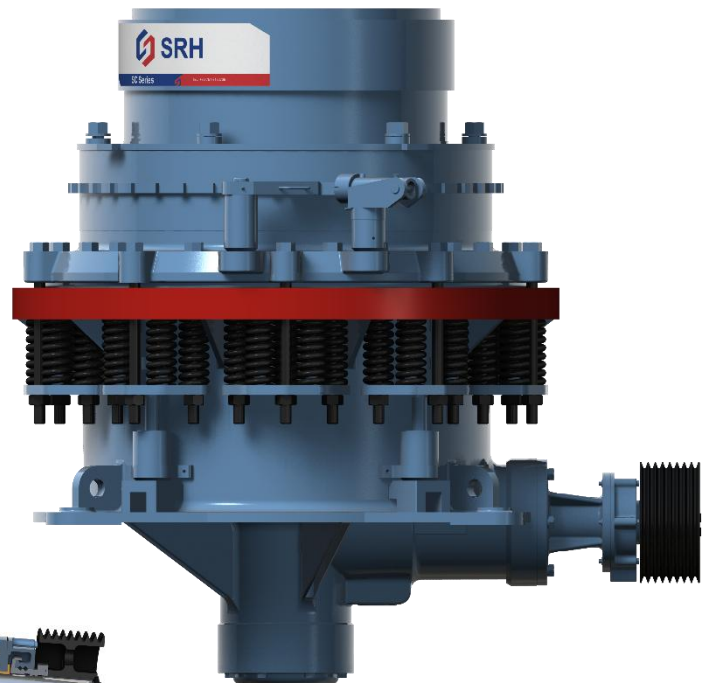
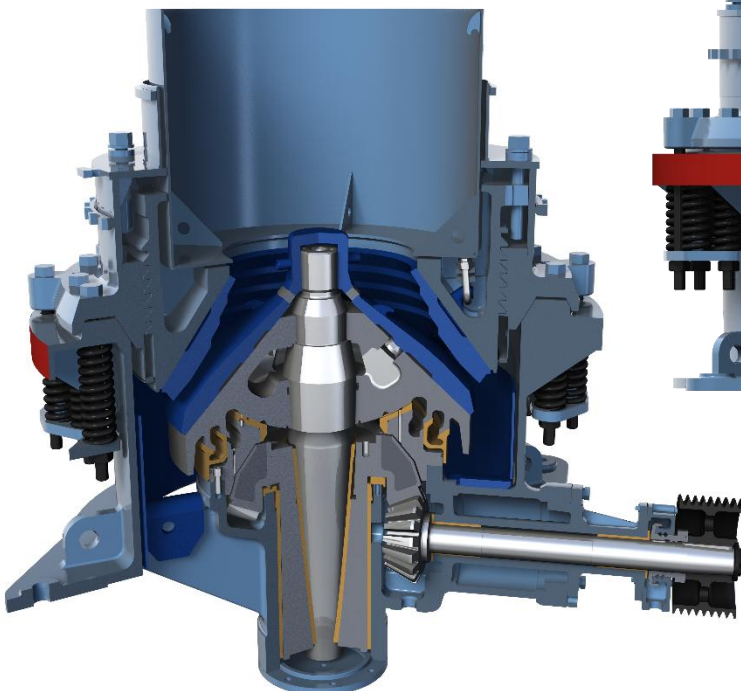

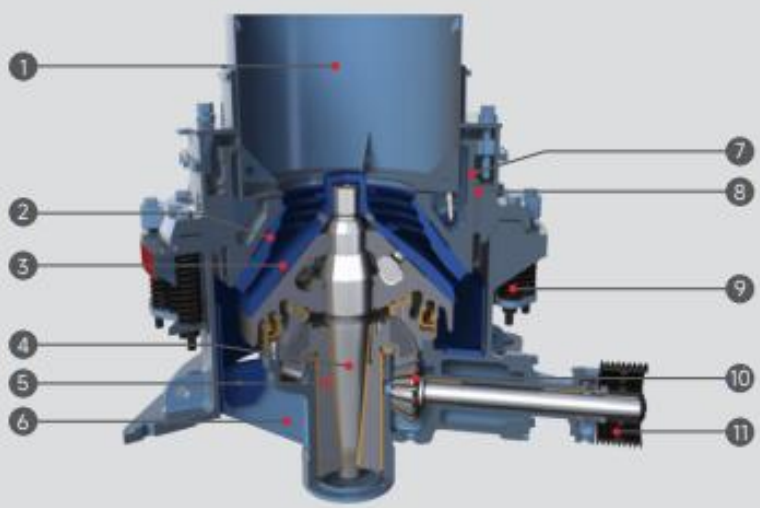

- 1 FEED HOPPER
- 2 CONCAVE
- 3 MANTLE
- 4 ECCENTRIC
- 5 ECCENTRIC SHAFT
- 6 FRAME
- 7 BOWL
- 8 ADJUSTMENT RING
- 9 SPRING
- 10 GEAR & PINION
- 11 PULLEY

Overall Dimensions

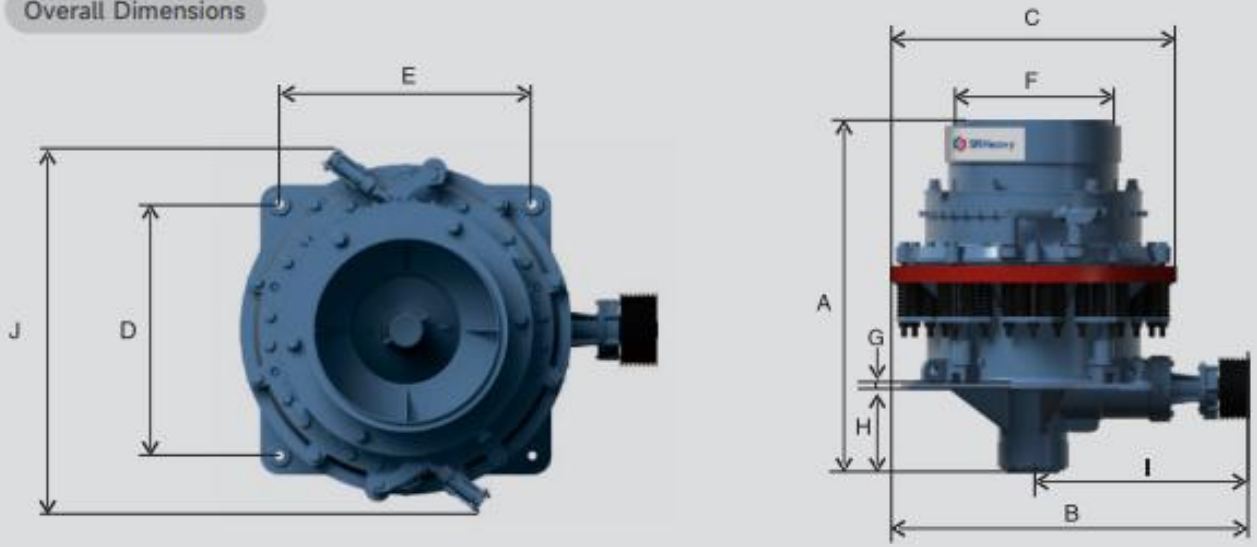

Product Gradation Curve

A	2390
B	2260
C	1760
D	1370
E	1370
F	970
G	48
H	535
I	1375
J	1848

