

SRH SC220

CONE CRUSHER

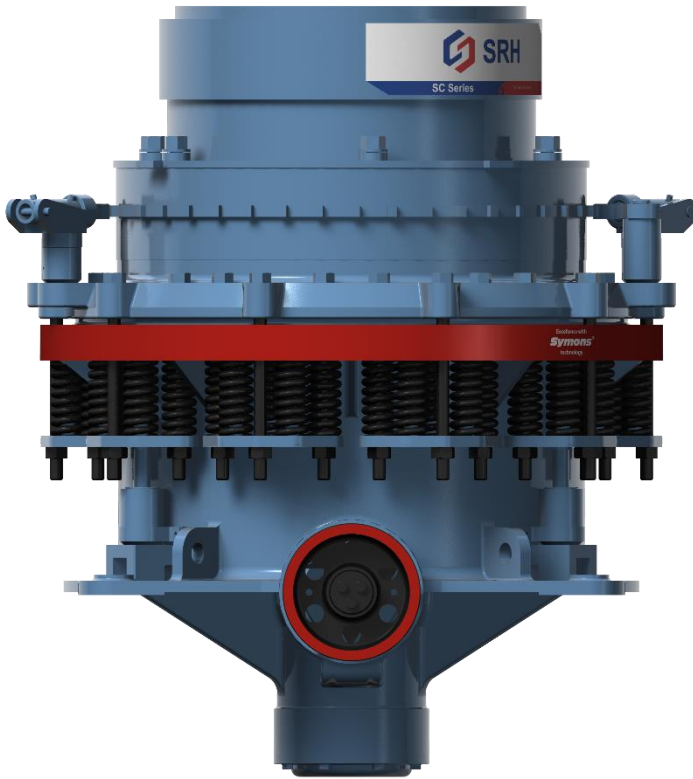

TECHNICAL DETAILS

Model	SC220Cone Base Unit
Capacity	90-450tph
CSS	6mm – 50mm
Max feed size	230mm
Installed power	220kW
Max lift	4500kg

DIMENSIONS

Weight	26,120kgs approx.
Length	2860mm
Width	2400mm
Height	2920mm

Note- Weight includes basic crusher and motor with anchoring fixings, v-belts for drive, control cabinet, motor support, lubrication station with hosing, fixing items, with easy transportation stack.

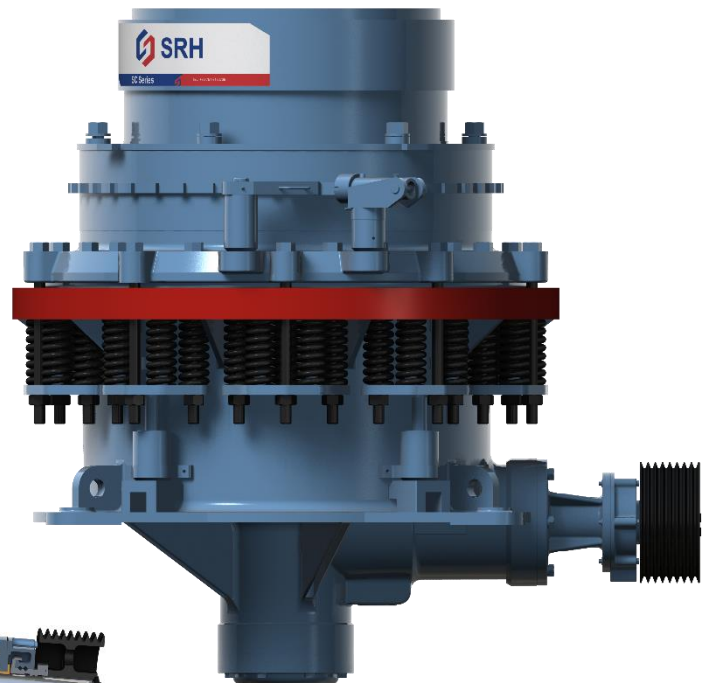
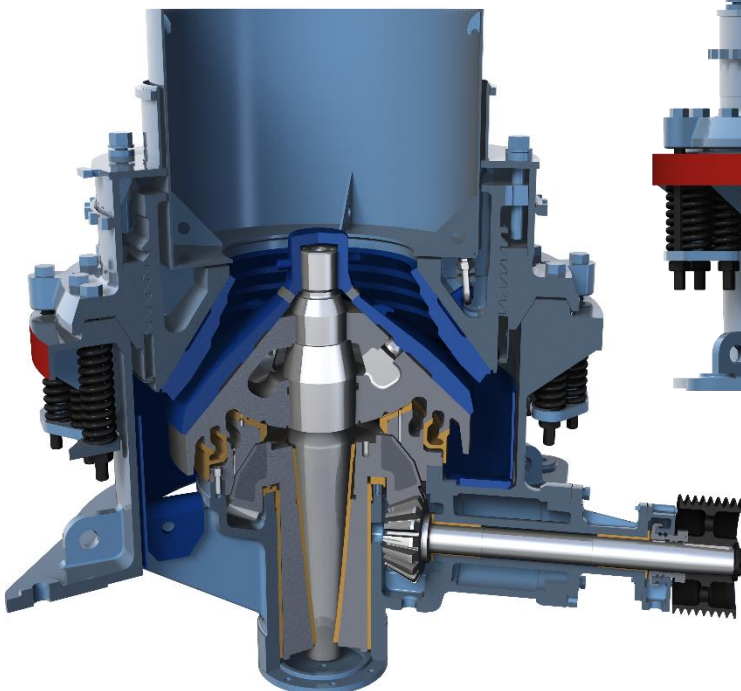

GENERAL ARRANGEMENT

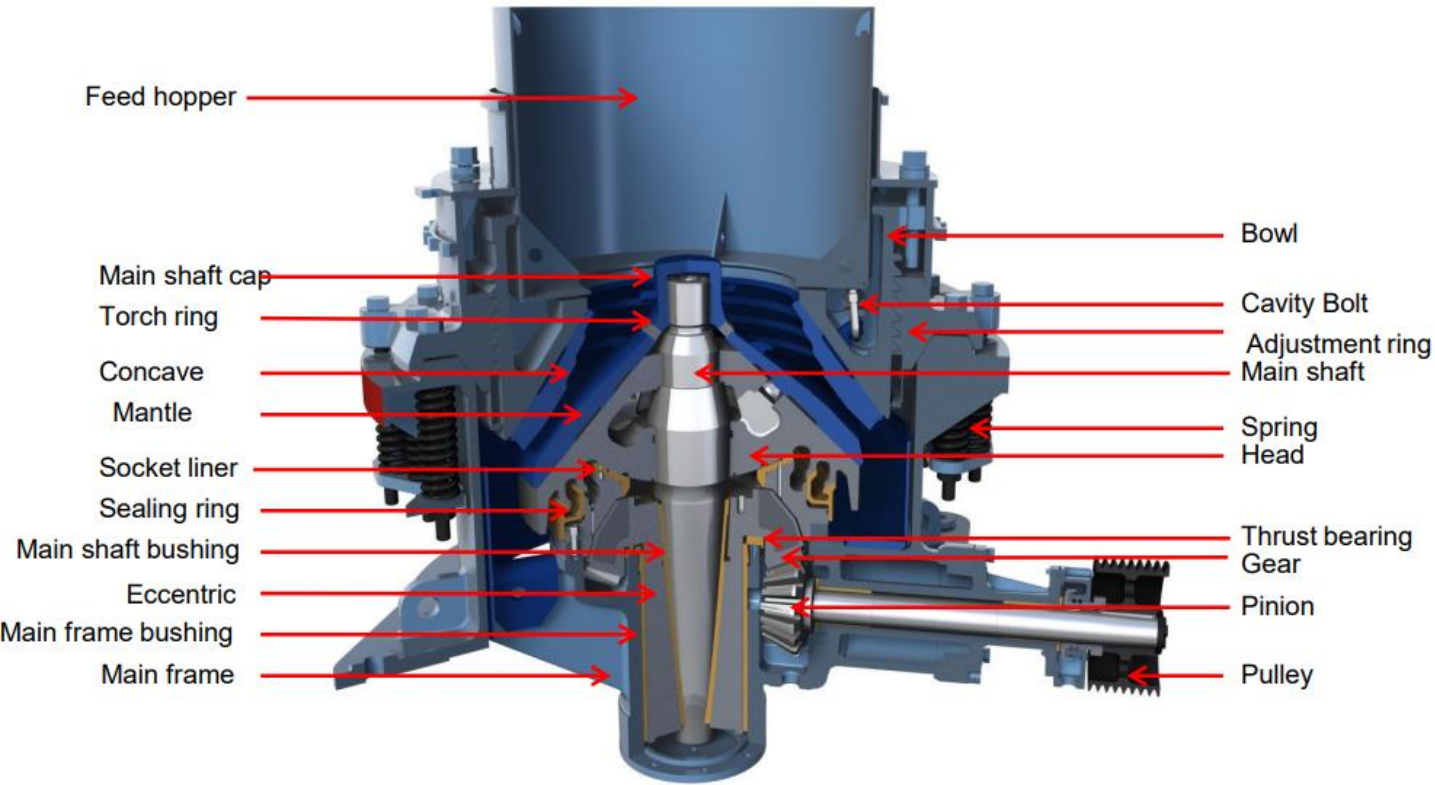

- An eccentric rotated by a gear and pinion produces a gyrating movement of the shaft line assembly.
- Crushing occurs between bowl liner and mantle. There is also inter-particle crushing between crushed particles

WORKING PRINCIPLE

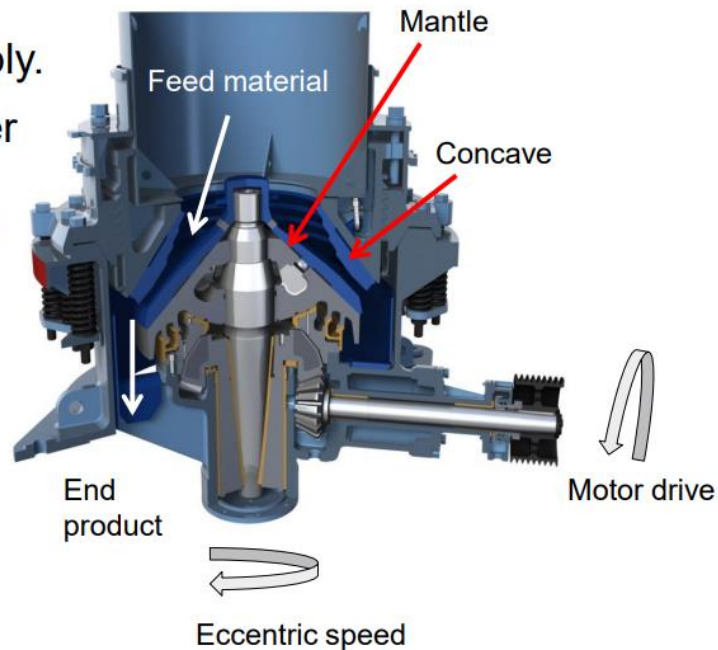



SC185

TEL: 0791-8136798

Excellence with
Symons[®]
technology



当心伤眼
Caution: injuries eye

