



TECHINAL DETAILS

Model	SCH2000 Base Unit
Capacity	90-250tph
CSS	10mm – 38mm
Max feed size	185mm
Installed power	132/160kW
Transmission	Driven by belts

DIMENSIONS

Weight	13,500kgs approx.
--------	-------------------

Note- Weight includes basic crusher and motor with anchoring fixings, v-belts for drive, control cabinet, motor support, lubrication station with hosing, fixing items, with sub frame.



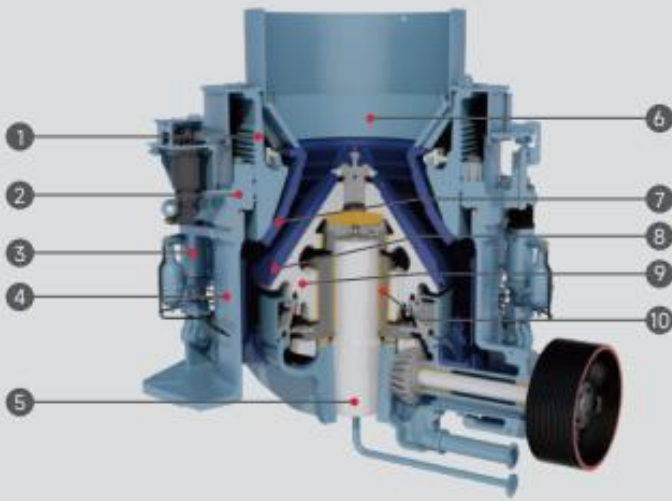

- 1 BOWL
- 2 ADJUSTMENT RING
- 3 TRAMP RELEASE ASSEMBLY
- 4 MAIN FRAME
- 5 MAIN SHAFT
- 6 FEED HOPER
- 7 CONCAVE
- 8 MANTLE
- 9 HEAD
- 10 ECCENTRIC SHAFT

A	297
B	1920
C	1160
D	914
E	1090

Overall Dimensions

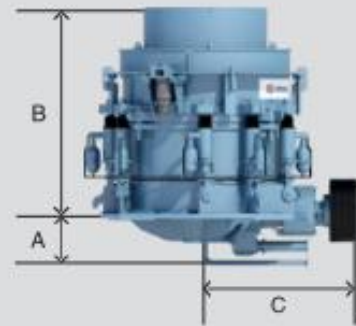
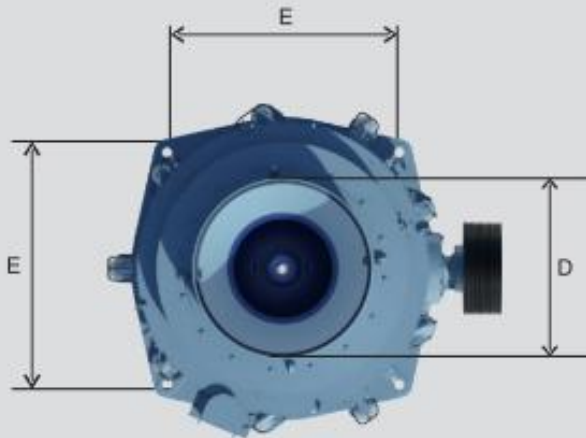

Product Gradation Curve

