



### TECHINAL DETAILS

Feed opening (W x H)	1522 x 827mm
Feed opening clearance	800mm
Max feed size	350mm
For hard materials	250mm
Rotor Diameter	1330mm
No. blow bars	4
Breaker plate	3 for secondary crushing
Installed power	220/280kW

**CAPACITY** 150-250tph

### DIMENSIONS

Width	2612mm
Length	2916mm
Height	3445mm
Weight	21769kgs approx.

Note- Weight includes basic crusher and motor with anchoring fixings, v-belts for drive, control cabinet, motor support, lubrication station, hydraulic station with piping

The SF1315 HSI features hydraulic frame opening and hoist for easy access to rotor and interior of crusher; high crushing ratio which in turn produces less stress on the product for a better shape & quality product. The SF1315 is suitable for a range of applications including constructions and quarries and secondary crushing with 3 breaker plate.

The SF series of impact crushers adopt a special crushing method, with a large crushing ratio, uniform particle size, cube shape, no tension and cracks, and a low proportion of needle-like materials. It can crush ores and various rocks whose high-pressure strength does not exceed 320MPa and whose feed particle size meets the requirements in the technical parameter table. This series of products adopts new technology that effectively prevents the entire impact frame from falling off and prevents the impact liner from colliding with the plate hammer, greatly enhancing the safety of the product.

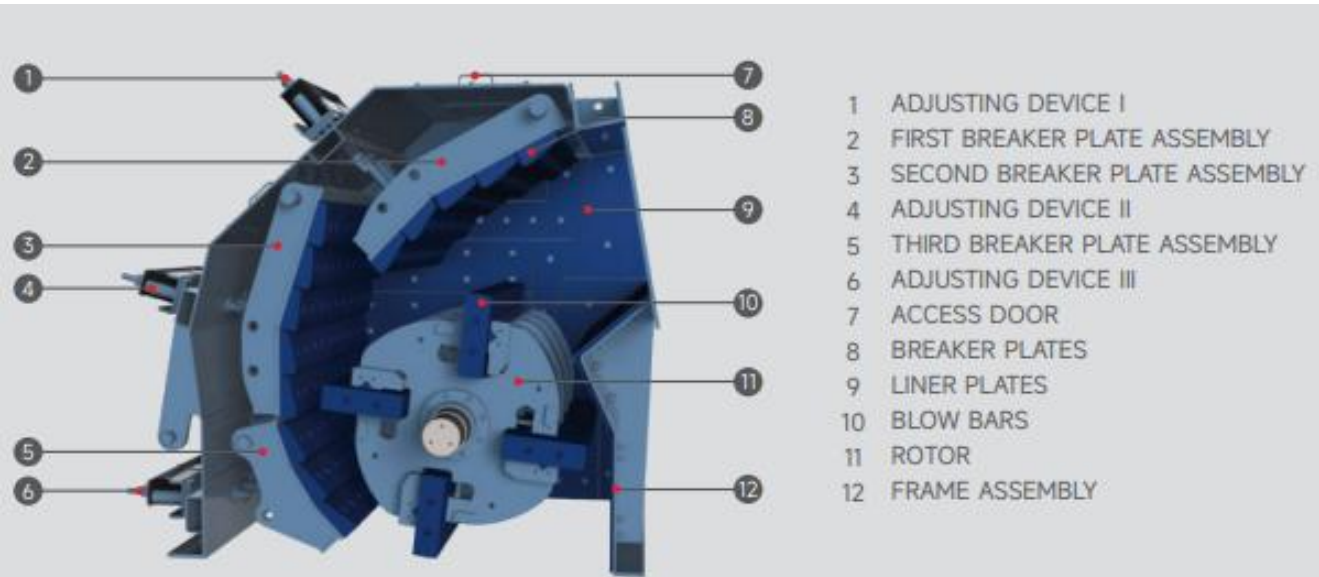

### Overall Dimensions

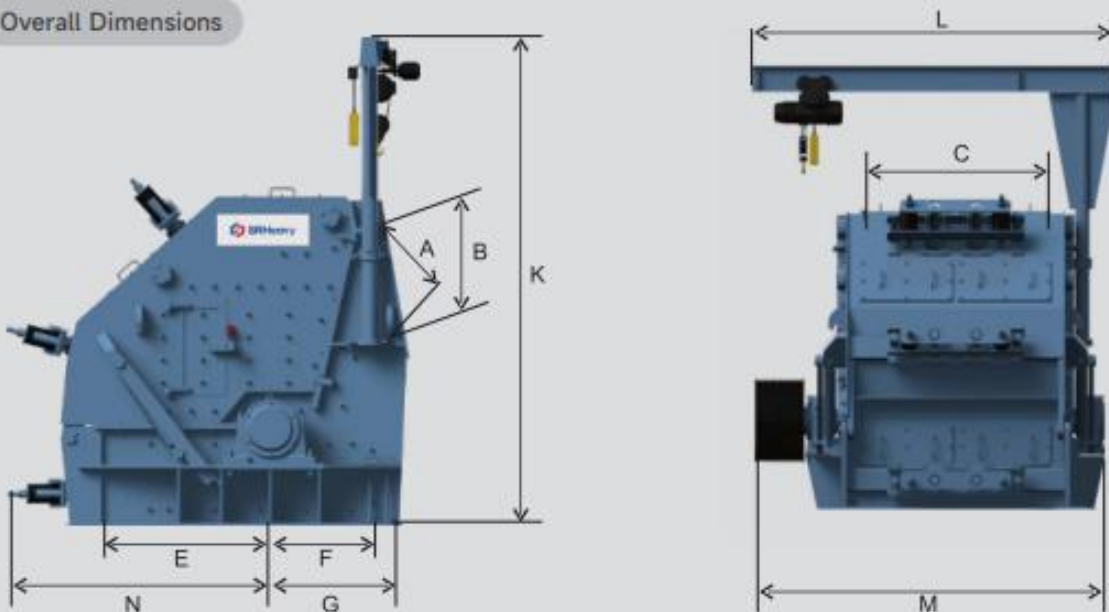

	A (mm)	B (mm)	C (mm)	E (mm)	F (mm)	G (mm)	K (mm)	L (mm)	M (mm)	N (mm)	Weight (kg)
--	--------	--------	--------	--------	--------	--------	--------	--------	--------	--------	-------------

SF1315	798	827	1522	1200	777	921	3445	2940	2612	1995	21769
--------	-----	-----	------	------	-----	-----	------	------	------	------	-------

韶瑞重工  
0751-8136739

韶瑞重工  
0751-8136739



