

# SRH SG260

## CONE CRUSHER

### TECHINAL DETAILS

<b>Model</b>	<b>SG260 Cone Base Unit</b>
<b>Capacity</b>	<b>135-190tph</b>
CSS	15mm – 40mm
Max feed size	205mm
Installed power	250kW
Max lift	4000kg
Stroke	25,32,40/28,36

### DIMENSIONS

Weight	19000kgs approx.
Length	2275mm
Width	1950mm
Height	3750mm

Note- Weight includes basic crusher and motor with anchoring fixings, v-belts for drive, control cabinet, motor support, lubrication station with hosing, fixing Items and Sub frame.



## Main Components

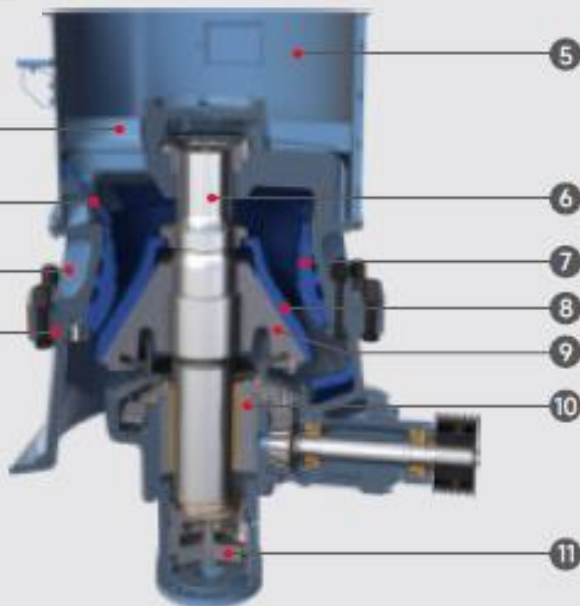

- 1 UPPER FRAME PROTECTION PLATE
- 2 FEED HOPPER LINER
- 3 UPPER FRAME
- 4 LOWER FRAME
- 5 FEED HOPPER
- 6 MAIN SHAFT
- 7 CONCAVE
- 8 MANTLE
- 9 HEAD
- 10 ECCENTRIC SHAFT
- 11 PISTON

## Overall Dimensions

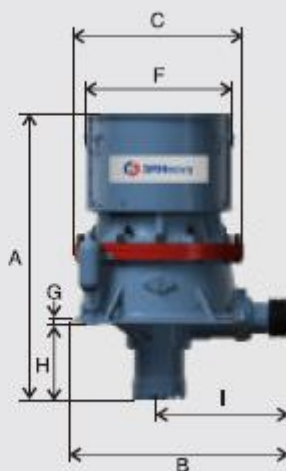
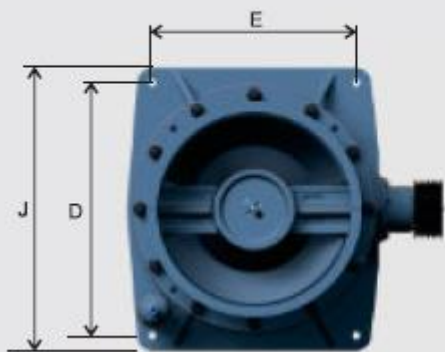

A	2950
B	2345
C	1860
D	1710
E	1385
F	1390
G	40
H	900
I	1410
J	2020

## Product Gradation Curve

