

SRH SG360S

CONE CRUSHER



TECHINAL DETAILS

Model	SG360S Cone Base Unit
Capacity	300-950tph
CSS	45mm – 80mm
Max feed size	442mm
Installed power	315kW
Max lift	12000kg
Stroke	18,25,32,40/28,36

DIMENSIONS

Weight	38100kgs approx.
Length	2776mm
Width	2600mm
Height	4437mm

Note- Weight includes basic crusher and motor with anchoring fixings, v-belts for drive, control cabinet, motor support, lubrication station with hosing, fixing Items and Sub frame.

Main Components

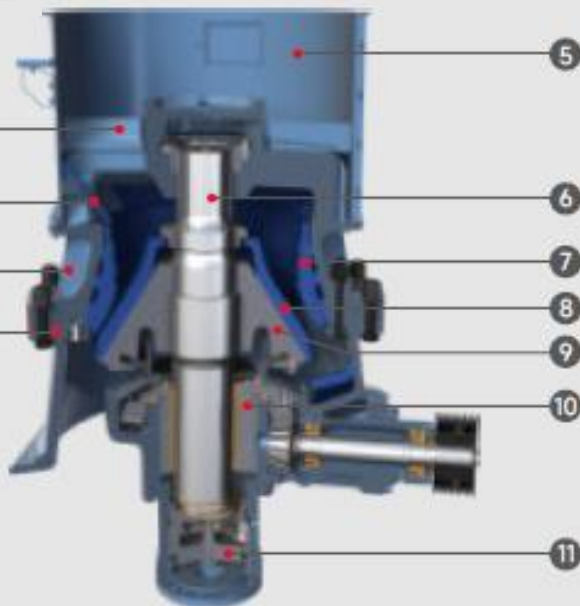

- 1 UPPER FRAME PROTECTION PLATE
- 2 FEED HOPPER LINER
- 3 UPPER FRAME
- 4 LOWER FRAME
- 5 FEED HOPPER
- 6 MAIN SHAFT
- 7 CONCAVE
- 8 MANTLE
- 9 HEAD
- 10 ECCENTRIC SHAFT
- 11 PISTON

Overall Dimensions

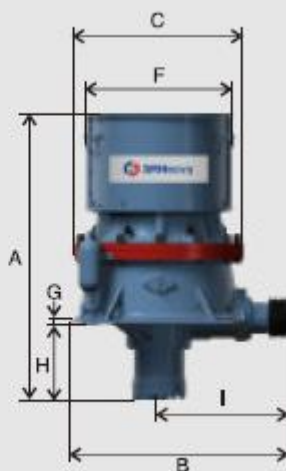
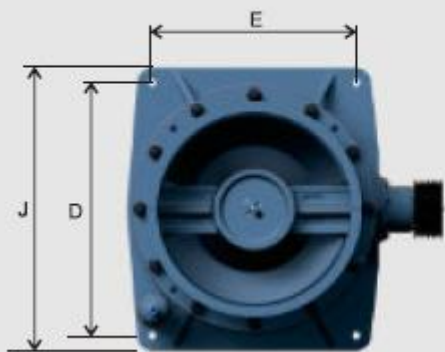

A	4437
B	2776
C	2280
D	2112
E	1592
F	2730
G	40
H	1152
I	1625
J	2600

Product Gradation Curve

