

# SRH SG560S

## CONE CRUSHER



### TECHINAL DETAILS

<b>Model</b>	<b>SG560S Cone Base Unit</b>
<b>Capacity</b>	<b>500-1130tph</b>
CSS	40mm – 90mm
Max feed size	410mm
Installed power	560kW
Max lift	24220kg
Stroke	32,36,40,45,50,54

### DIMENSIONS

Weight	82200kgs approx.
Length	3026mm
Width	3470mm
Height	6059mm

Note- Weight includes basic crusher and motor with anchoring fixings, v-belts for drive, control cabinet, motor support, lubrication station with hosing, fixing Items and Sub frame.

## Main Components

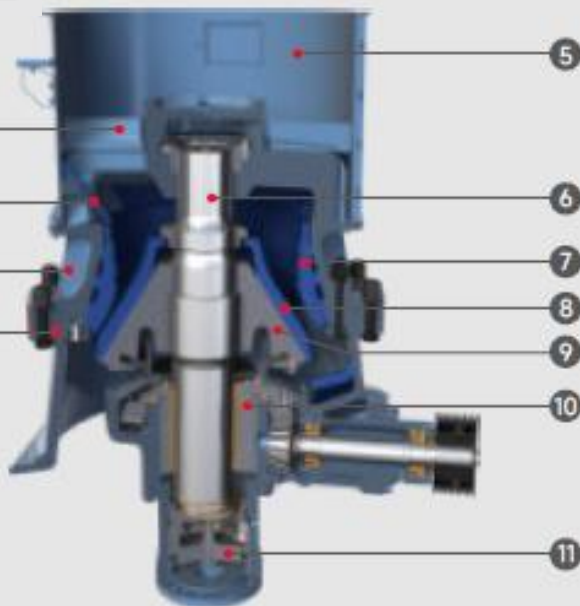

- 1 UPPER FRAME PROTECTION PLATE
- 2 FEED HOPPER LINER
- 3 UPPER FRAME
- 4 LOWER FRAME
- 5 FEED HOPPER
- 6 MAIN SHAFT
- 7 CONCAVE
- 8 MANTLE
- 9 HEAD
- 10 ECCENTRIC SHAFT
- 11 PISTON

## Overall Dimensions

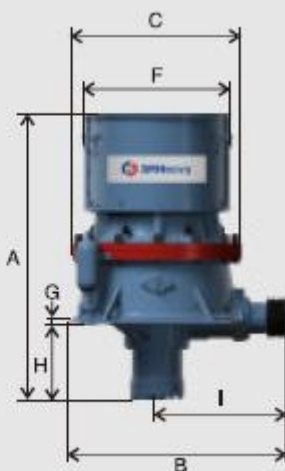
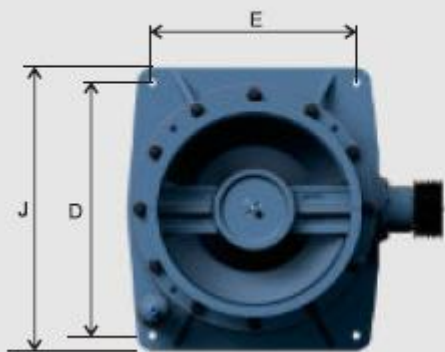

A	6059
B	3470
C	2630
D	2490
E	2490
F	2810
G	57
H	1646
I	2094
J	3026

## Product Gradation Curve

