



TECHINAL DETAILS

Model	SJ1100 Base Unit
Capacity	195-410tph
Feed opening (W x H)	1060 x 750mm
Max feed size	630mm
CSS	100-250
Installed power	110kW
Adjustment	Manual with shims
Max lifting weight	13000kg

DIMENSIONS

Width	2409mm
Length	2996mm
Height	2831mm
Weight	27100kgs approx.

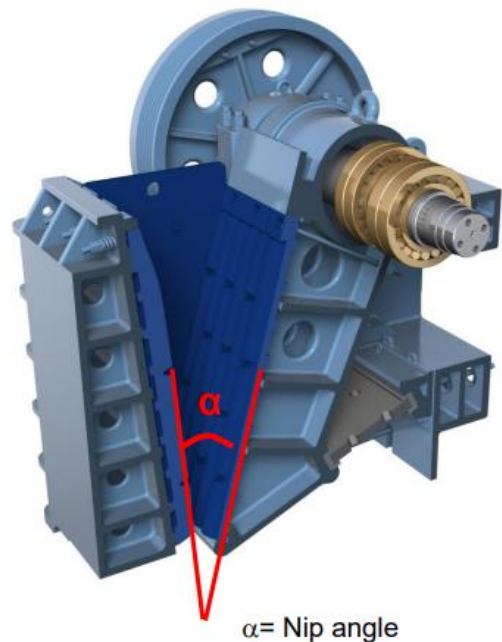
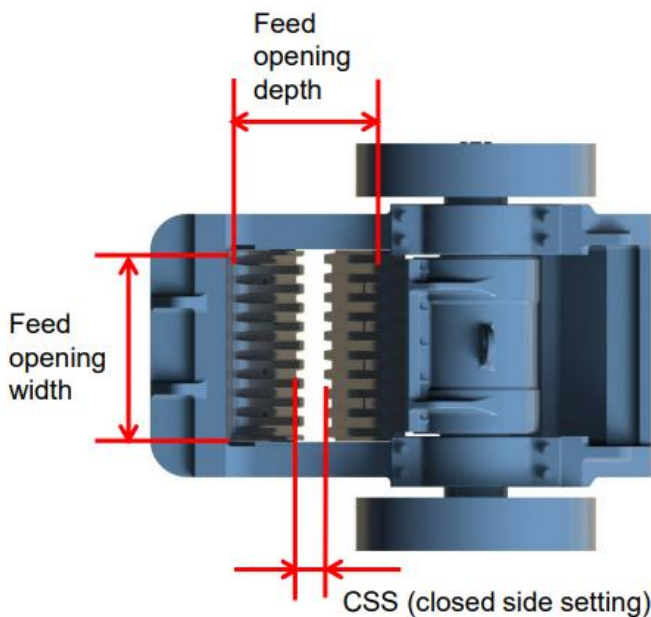

Main Components

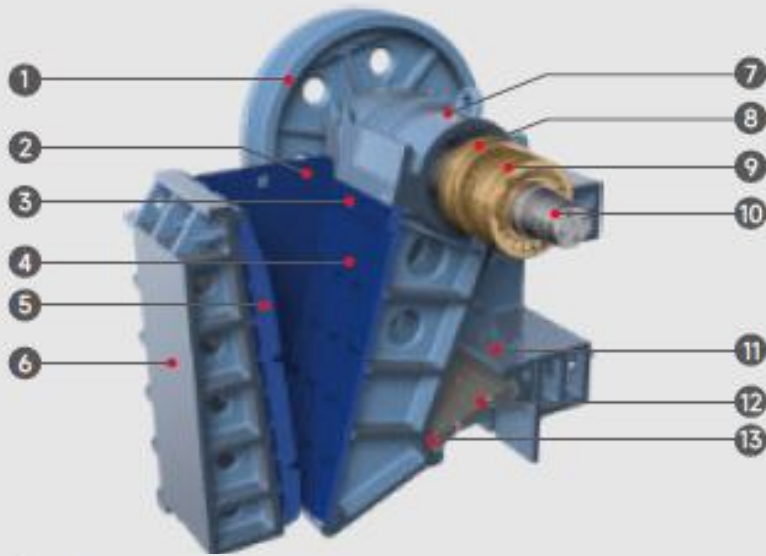

- 1 FLYWHEEL
- 2 CHEEK PLATE
- 3 TIGHTENING WEDGE
- 4 MOVABLE JAW PLATE
- 5 FIXED JAW PLATE
- 6 FRAME
- 7 PITMAN
- 8 PITMAN BEARING
- 9 FRAME BEARING
- 10 ECCENTRIC SHAFT
- 11 ADJUSTING TOGGLE SEAT
- 12 TOGGLE PLATE
- 13 TOGGLE SEAT

Overall Dimensions

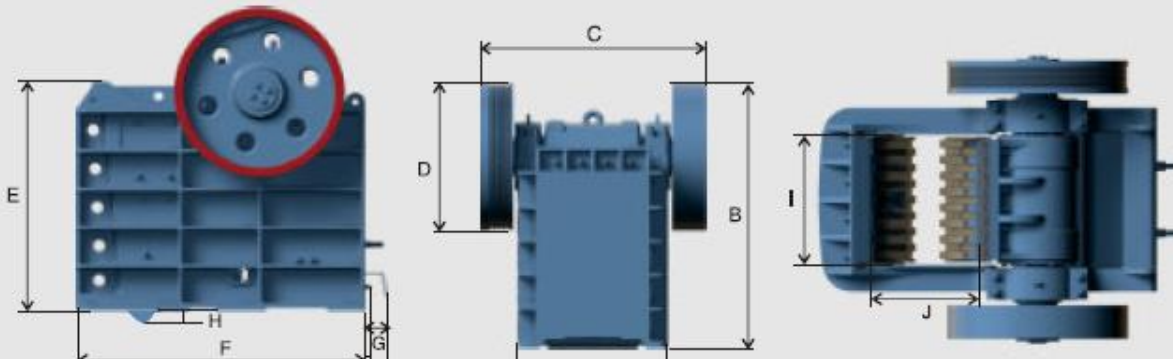

A	1595
B	2831
C	2409
D	1650
E	2108
F	2566
G/K	430G
H	60
I	1060
J	750

Product Gradation Curve

