

SRH SJ1800

JAW CRUSHER



TECHINAL DETAILS

Model	SJ1800 Base Unit
Capacity	622-1150tph
Feed opening (W x H)	1800 x 1500mm
Max feed size	1200mm
CSS	180-320
Installed power	355kW
Adjustment	Hydraulically assisted
Max lifting weight	49900kg

DIMENSIONS

Width	3830mm
Length	5020mm
Height	4695mm
Weight	125,000kgs approx.

Note: Weight includes basic crusher and motor with anchoring fixing. V-belts for drive, starter cabinet motor support.

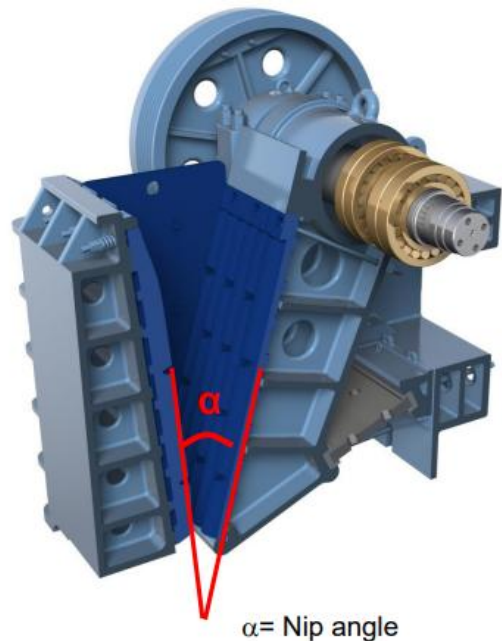
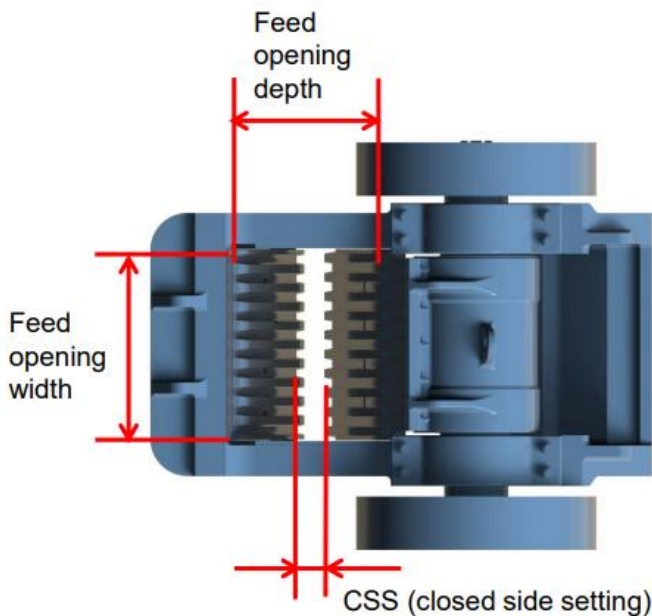

Main Components

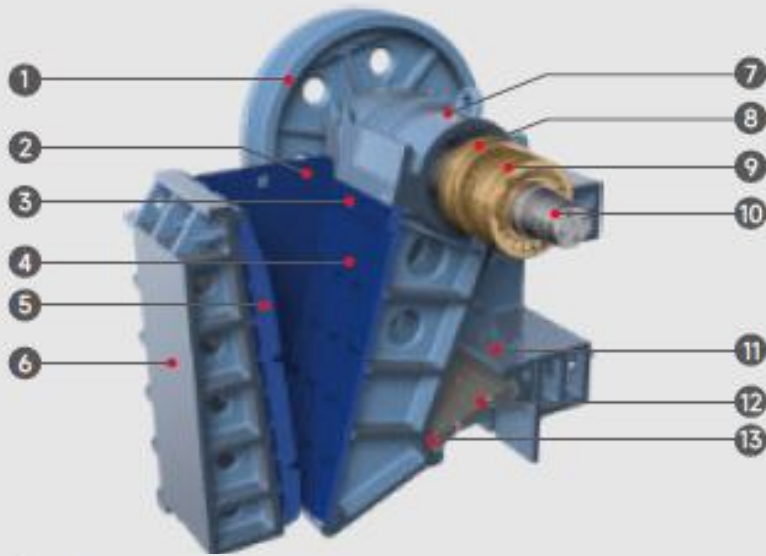

- 1 FLYWHEEL
- 2 CHEEK PLATE
- 3 TIGHTENING WEDGE
- 4 MOVABLE JAW PLATE
- 5 FIXED JAW PLATE
- 6 FRAME
- 7 PITMAN
- 8 PITMAN BEARING
- 9 FRAME BEARING
- 10 ECCENTRIC SHAFT
- 11 ADJUSTING TOGGLE SEAT
- 12 TOGGLE PLATE
- 13 TOGGLE SEAT

Overall Dimensions

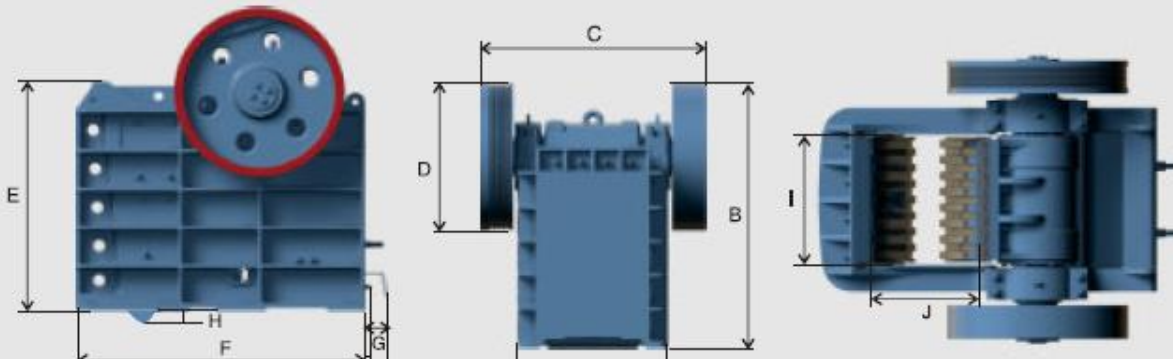

A	2460
B	4695
C	3830
D	2230
E	3810
F	4700
G/K	320 (G)
H	185
I	1800
J	1500

Product Gradation Curve

