

VERTICAL SHAFT IMPACTOR

TECHINAL DETAILS

Model	SV10 R260 Base Unit
Capacity	145-220tph
Tip speed	45-75 m/s
Max feed size	40mm
Installed power	260kW
Rotor Speed	1230-1470
Max lift	3500kg

DIMENSIONS

Weight	14986kgs approx.
Length	5179mm
Width	3090mm
Height	2944mm

Note- Weight includes basic crusher, starting cabinet, rotor balancing device, tools, motors, v-belts for drives

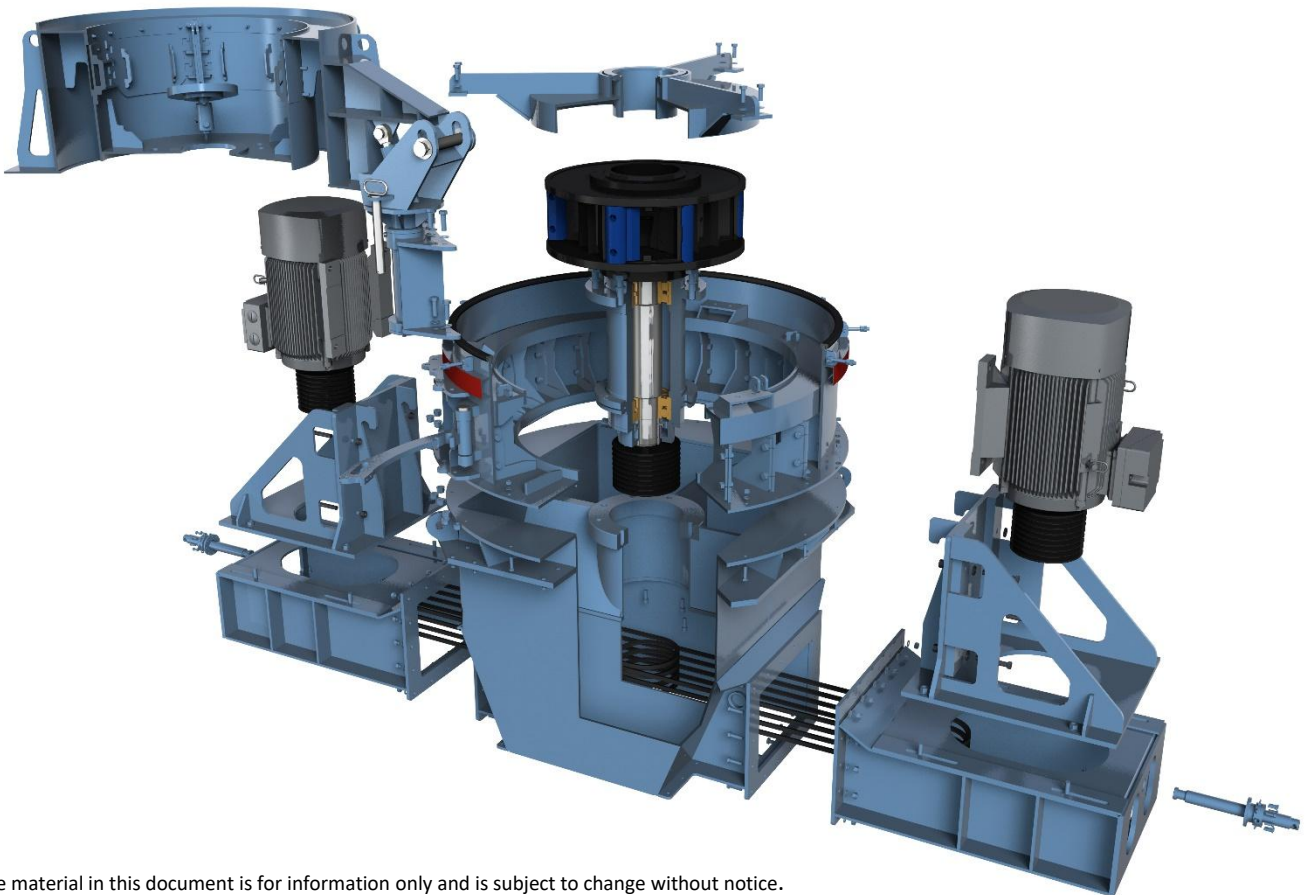
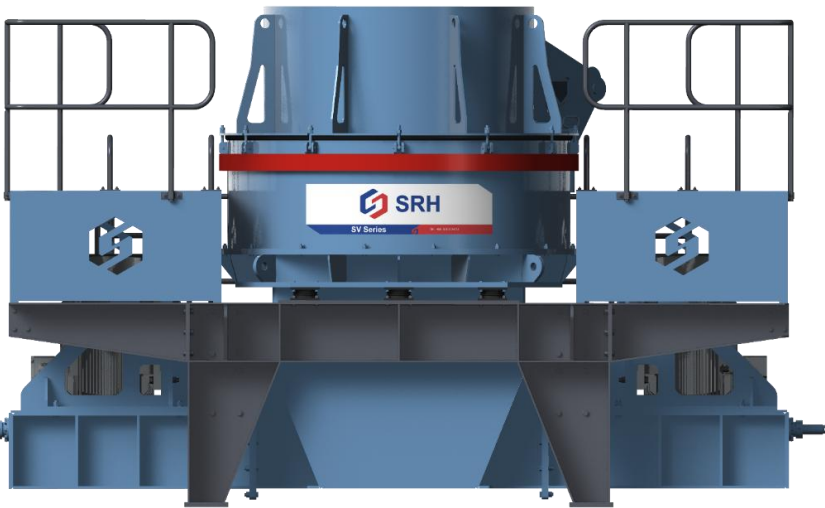

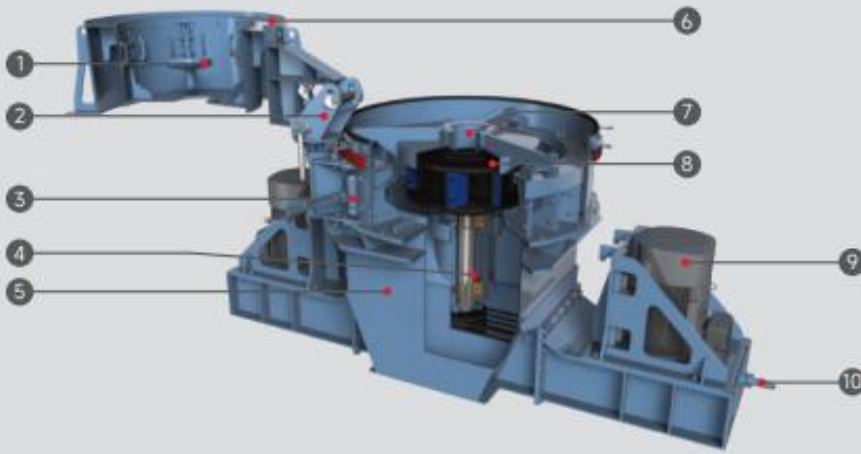

- 1 SPREADER PLATE
- 2 ROOF LIFTER
- 3 DOOR
- 4 SHAFT LINE ASSEMBLY
- 5 CRUSHER BASE
- 6 HOPPER
- 7 FEED TUBE
- 8 ROTOR
- 9 MOTOR
- 10 ADJUSTMENT ROD

Overall Dimensions

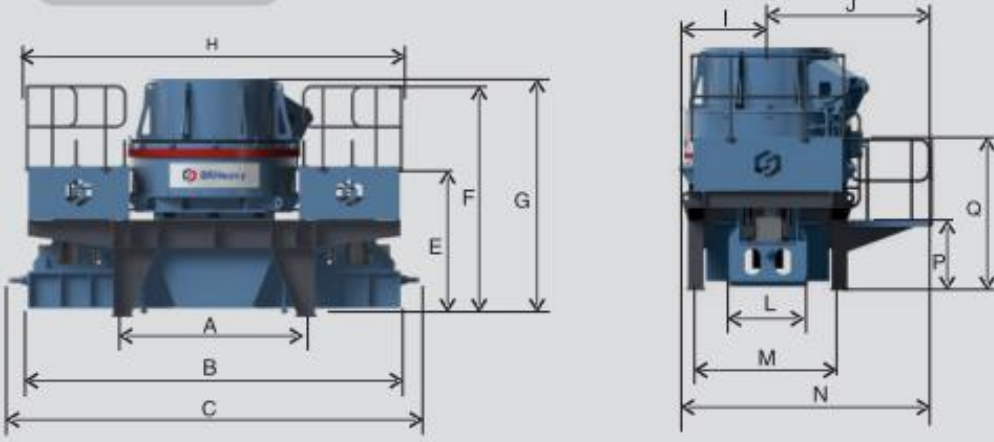

A	2280
B	4620
C	5101
E	1773
F	2791
G	2850
H	4664
I	2170
J	2010
L	950
M	1748
N	3090
P	860
Q	1860

Product Gradation Curve

