

## VERTICAL SHAFT IMPACTOR

### TECHINAL DETAILS

<b>Model</b>	<b>SV10 R320 Base Unit</b>
<b>Capacity</b>	<b>175-265tph</b>
Tip speed	45-75 m/s
Max feed size	40mm
Installed power	300kW
Tip Speed	45-75
Max lift	3500kg

### DIMENSIONS

Weight	15396kgs approx.
Length	5179mm
Width	3090mm
Height	2944mm

Note- Weight includes basic crusher, starting Cabinet, rotor balancing device, tools, motors, v-belts for drives



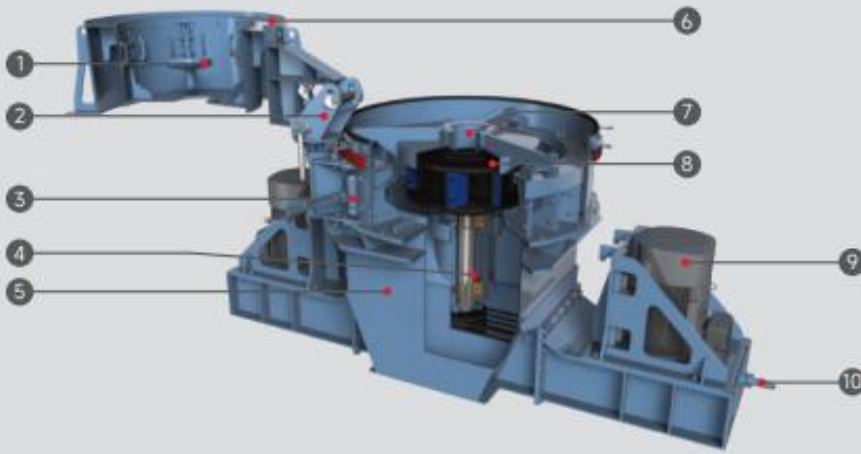

- 1 SPREADER PLATE
- 2 ROOF LIFTER
- 3 DOOR
- 4 SHAFT LINE ASSEMBLY
- 5 CRUSHER BASE
- 6 HOPPER
- 7 FEED TUBE
- 8 ROTOR
- 9 MOTOR
- 10 ADJUSTMENT ROD

Overall Dimensions

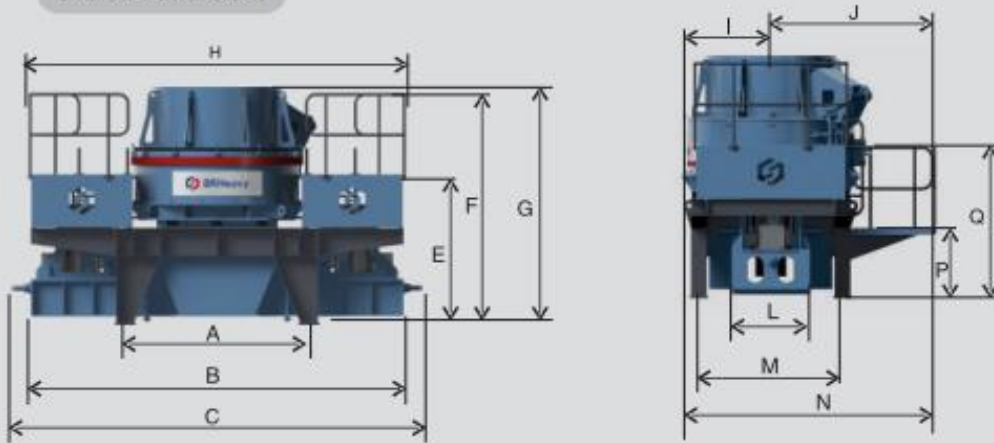

A	2280
B	4620
C	5179
E	1773
F	2791
G	2850
H	4664
I	2170
J	2010
L	950
M	1748
N	3090
P	860
Q	1860

Product Gradation Curve

