



### TECHNICAL DETAILS

<b>Model</b>	<b>SV10D R400 Base Unit</b>
<b>Capacity</b>	<b>250-400tph</b>
Max feed size	40mm
Installed power	2 x 200kW
Tip Speed m/s	45-75
Max lift	3850kg

### DIMENSIONS

Weight	17404kgs approx.
Length	5647mm
Width	3207mm
Height	3061mm

Note- Weight includes basic crusher, starting Cabinet, rotor balancing device, tools, motors, v-belts for drives



## Main Components

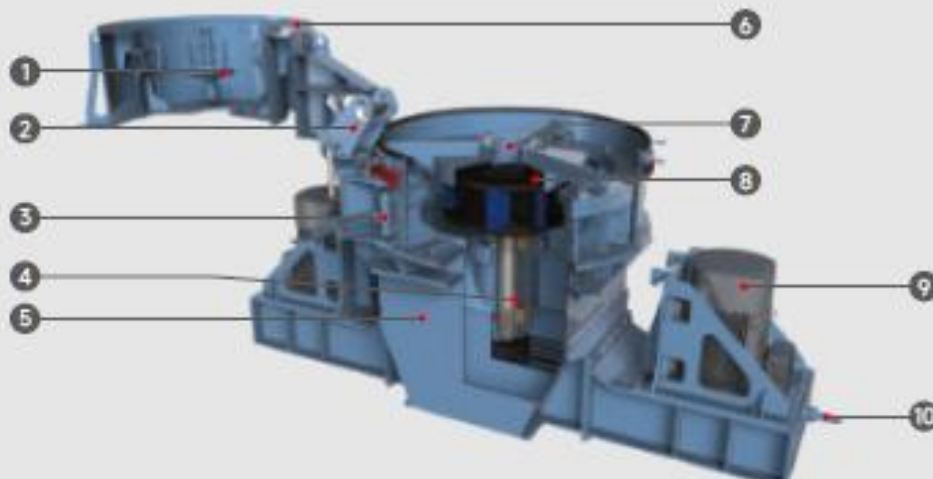

- 1 SPREADER PLATE
- 2 ROOF LIFTER
- 3 DOOR
- 4 SHAFT LINE ASSEMBLY
- 5 CRUSHER BASE
- 6 HOPPER
- 7 FEED TUBE
- 8 ROTOR
- 9 MOTOR
- 10 ADJUSTMENT ROD

## Overall Dimensions

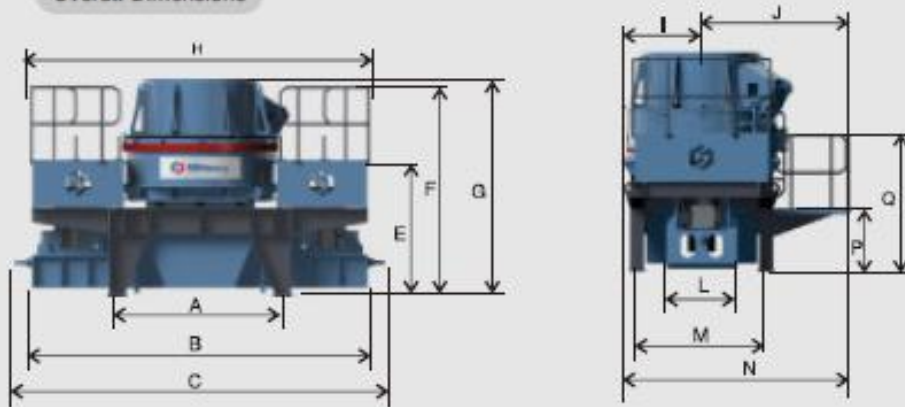

A	2340
B	5088
C	5647
E	1883
F	2901
G	2964
H	5142
I	2310
J	2052
L	1040
M	1838
N	3207
P	973
Q	1973

## Product Gradation Curve

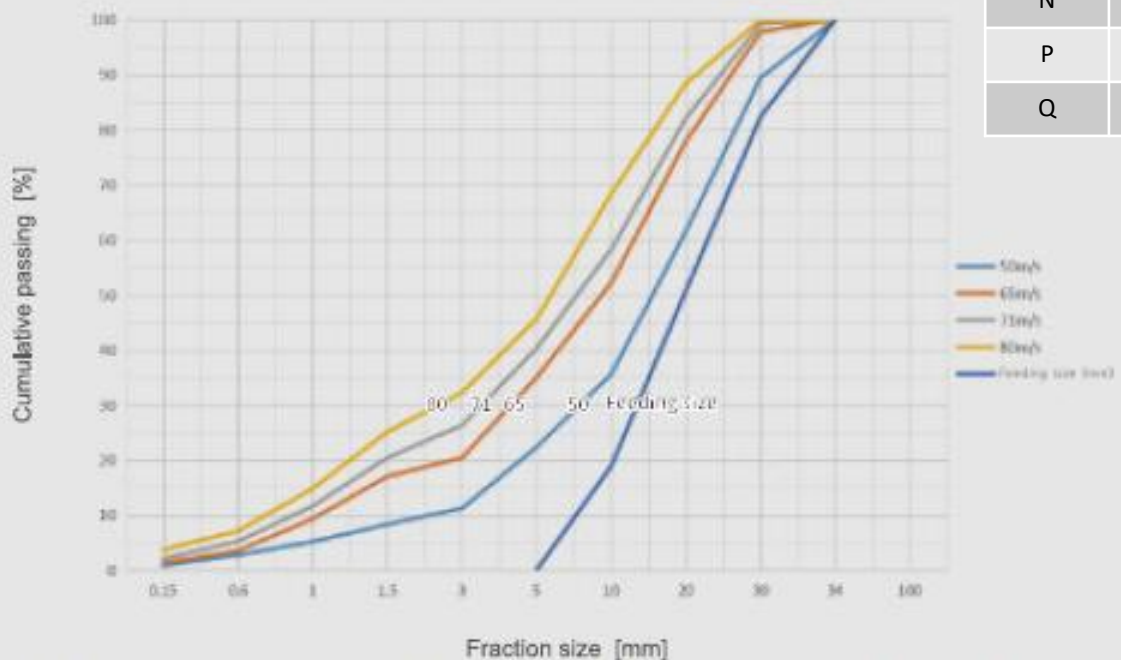

Output product gradation are subject to factors such as physical properties of feed material , feeding method, feed size and curve.