

TECHNICAL DETAILS

| | |
|----------------------|-------------------------------------|
| Model | SJC165 Base Unit Jaw Crusher |
| Capacity | 450-1200tph |
| Feed opening (W x H) | 1600 x 1125mm |
| Max feed size | 960mm |
| Adjustment | Hydraulic wedges |
| Rotate speed | 220rpm |
| CSS range | 150-300mm |
| Installed power | 315kW |
| Drive | V belts |
| Max lifting weight | 34,000kg |
| Adjustment mode | Hydraulic adjustment |

DIMENSIONS

| | |
|--------|-------------------|
| Width | 5557mm |
| Length | 3413mm |
| Height | 5152mm |
| Weight | 90,000kgs approx. |

Note: Weight includes basic crusher, motor and Anchoring fixing, V-belts for drive, starter cabinet Motor support.

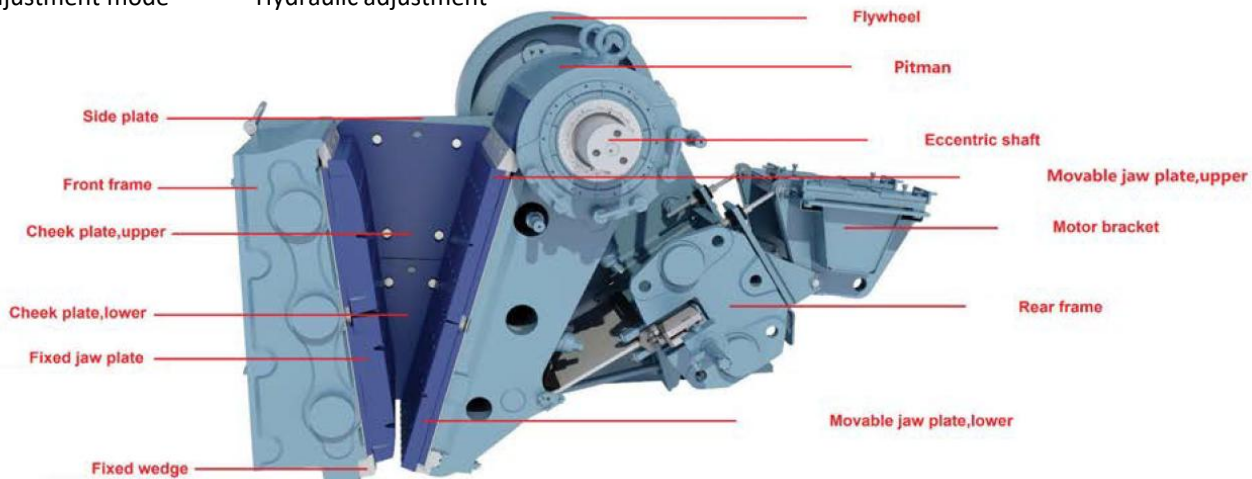

Main Components

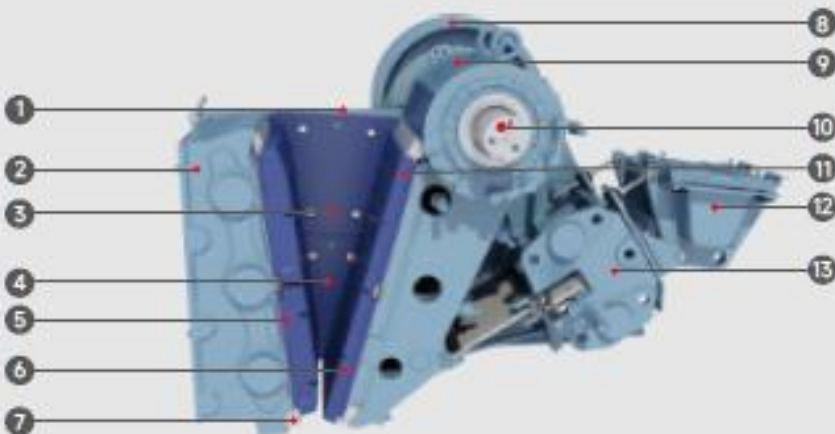

- 1 SIDE PLATE
- 2 FRONT FRAME
- 3 CHEEK PLATE, UPPER
- 4 CHEEK PLATE, LOWER
- 5 FIXED JAW PLATE
- 6 MOVABLE JAW PLATE, LOWER
- 7 FIXED WEDGE
- 8 FLYWHEEL
- 9 PITMAN
- 10 ECCENTRIC SHAFT
- 11 MOVABLE JAW PLATE, UPPER
- 12 MOTOR BRACKET
- 13 REAR FRAME

Overall Dimensions

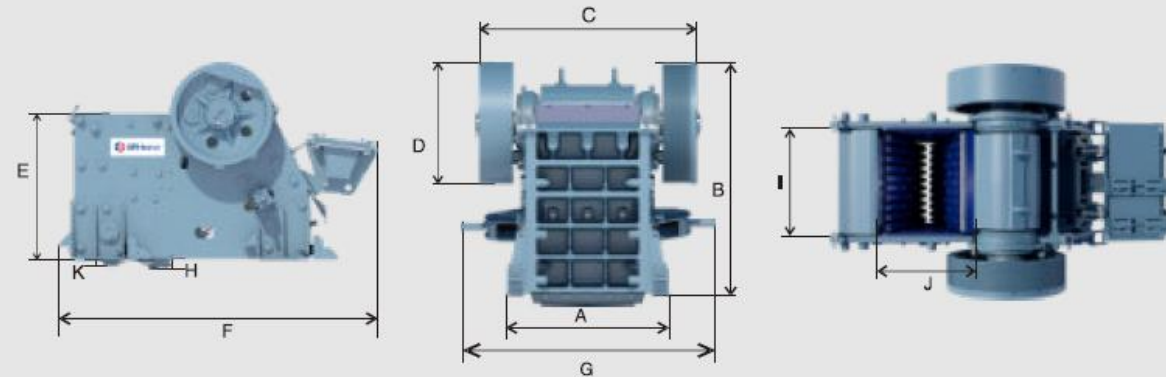

| | |
|---|------|
| A | 2415 |
| B | 3729 |
| C | 3142 |
| D | 1800 |
| E | 2975 |
| F | 5564 |
| G | 3369 |
| K | 253 |
| H | 232 |
| I | 1600 |
| J | 1200 |

Product Gradation Curve

