

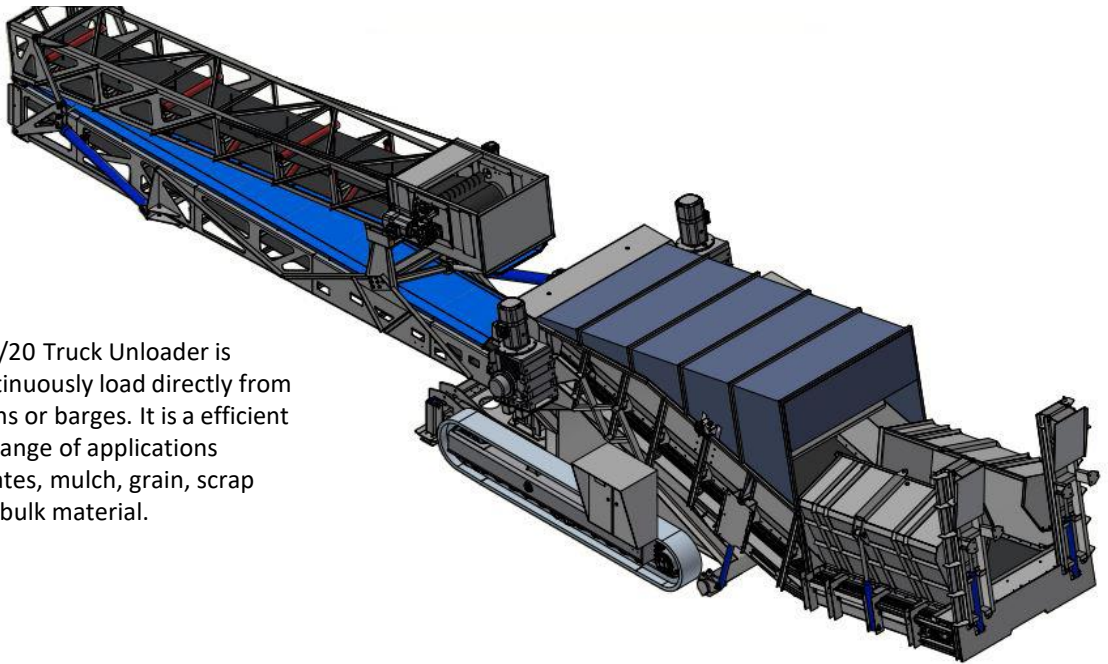

MTTU2200/20

TRUCK UNLOADER



The Convir MTTU2200/20 Truck Unloader is designed to allow continuously load directly from trucks into train wagons or barges. It is a efficient loading method for a range of applications including coal, aggregates, mulch, grain, scrap metal, or virtually any bulk material.

MOBILE TRUCK UNLOADER

Radial Conveyor Length	20m
Conveyor belt	2200 EP500/3 4+2
Conveyor belt	1000 EP500/3 4+2
Radial movement	120°
Max unloading height	8m
Capacity	Up to 500tph
Heavy duty sprockets	
Heavy duty chain	
Gearbox (truck unloader)	2xpcs 22kW
Gearbox (radial conveyor)	15kW
Drive motor lagged	
Hydraulic station (tracks)	30kW
Hydraulic station (cylinders)	7.5kW
Double sealing through all length truck unloader	
Ramps for truck wheels integrated	
Heavy duty metal tracks with rubber coverings	
500mm length 400mm width	
Automation control cabinet & remote control	
Truck unloader drum motor	
Feeder chute	
Diesel generator for tracks driving	
Radial conveyor overed with covers	
Water fog nozzles on radial conveyor loading & driving end	

TRANSPORT DIMENSIONS

Length	20145mm
Height	4700mm
Width	4880mm
Weight	35,000kgs approx.

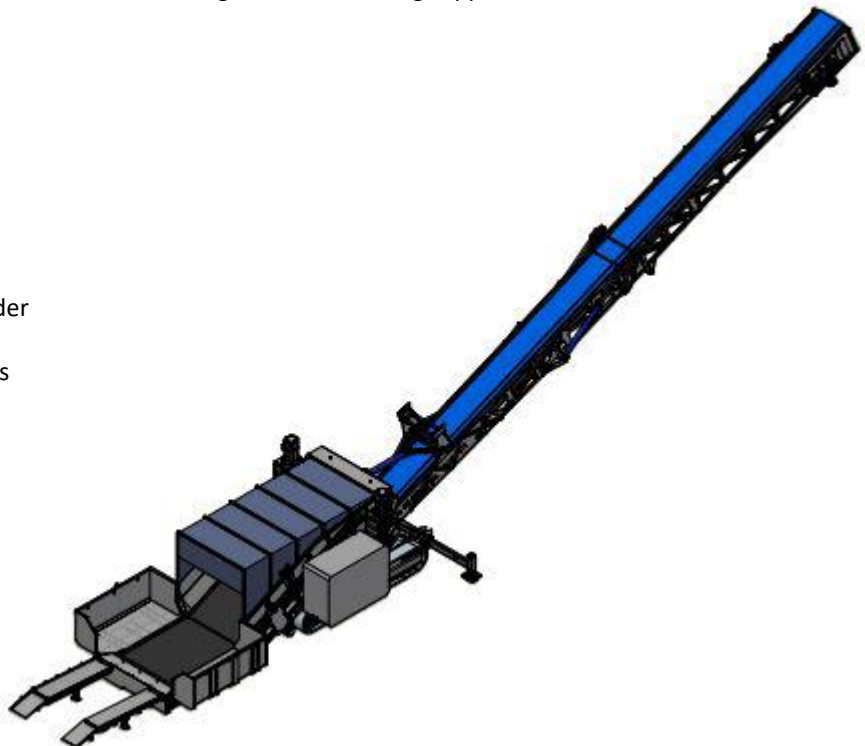



MTTU2200/20