



TECHINAL DETAILS

Feed opening (W x H)	1330 x 782mm
Max feed size	250mm
For hard materials	
Max feed size	600mm
Rotor Diameter	1200mm
Installed power	250kW

CAPACITY	120-350tph
-----------------	------------

DIMENSIONS

Width	2540mm
Length	2761mm
Height	3255mm
Weight	14060kgs approx.

Note- Weight includes basic crusher and motor with anchoring fixings, v-belts for drive, control cabinet, motor support, lubrication station, hydraulic station with piping

The SF1213 HSI features hydraulic frame opening and hoist for easy access to rotor and interior of crusher; high crushing ratio and capacity with large gripping angle, in turn produces less stress on the product for a better shape & quality product. The SF1213 is suitable for a range of applications including constructions and quarries.

The SF series of impact crushers adopt a special crushing method, with a large crushing ratio, uniform particle size, cube shape, no tension and cracks, and a low proportion of needle-like materials. It can crush ores and various rocks whose high-pressure strength does not exceed 320MPa and whose feed particle size meets the requirements in the technical parameter table. This series of products adopts new technology that effectively prevents the entire impact frame from falling off and prevents the impact liner from colliding with the plate hammer, greatly enhancing the safety of the product.

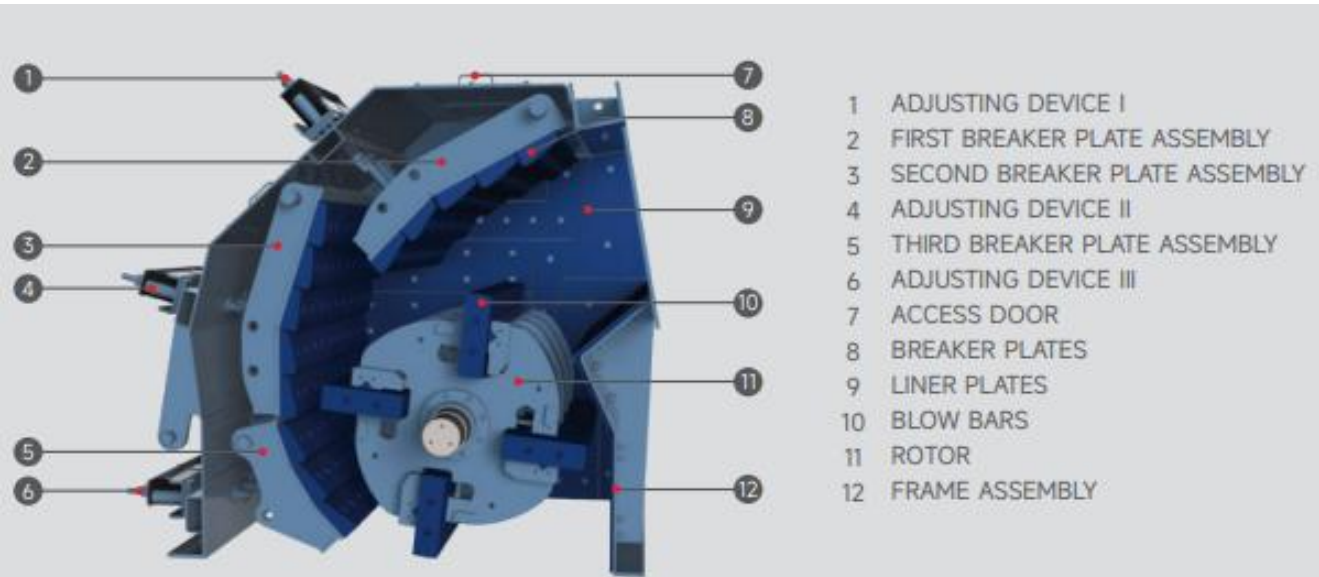

Overall Dimensions

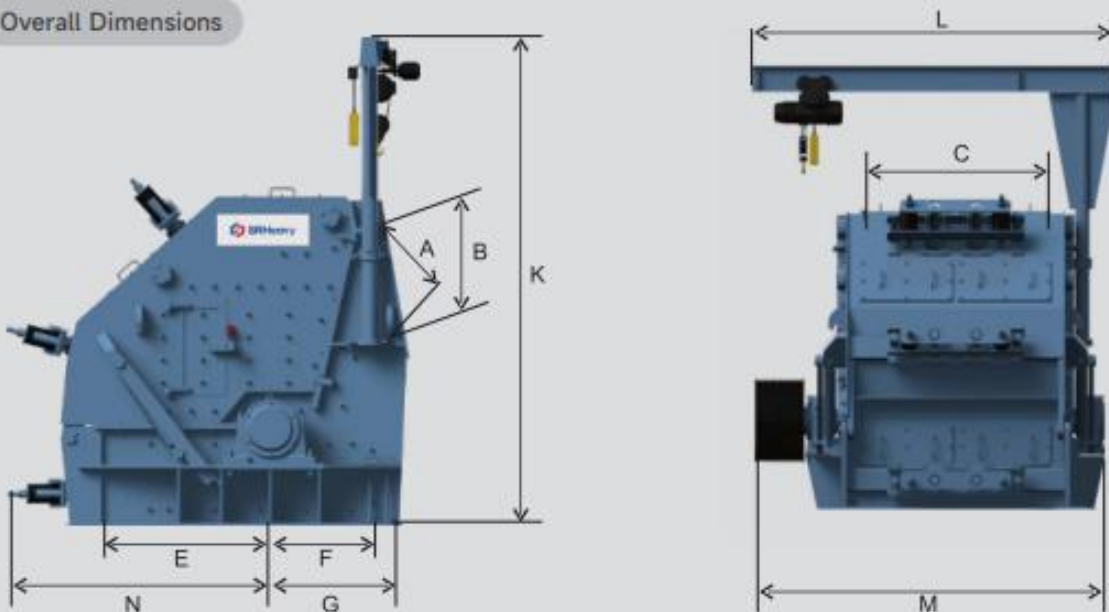

	A (mm)	B (mm)	C (mm)	E (mm)	F (mm)	G (mm)	K (mm)	L (mm)	M (mm)	N (mm)	Weight (kg)
--	--------	--------	--------	--------	--------	--------	--------	--------	--------	--------	-------------

SF1213	782	915	1330	1147	683	827	3255	2540	2242	1934	17479
--------	-----	-----	------	------	-----	-----	------	------	------	------	-------

21
系列
NEW F

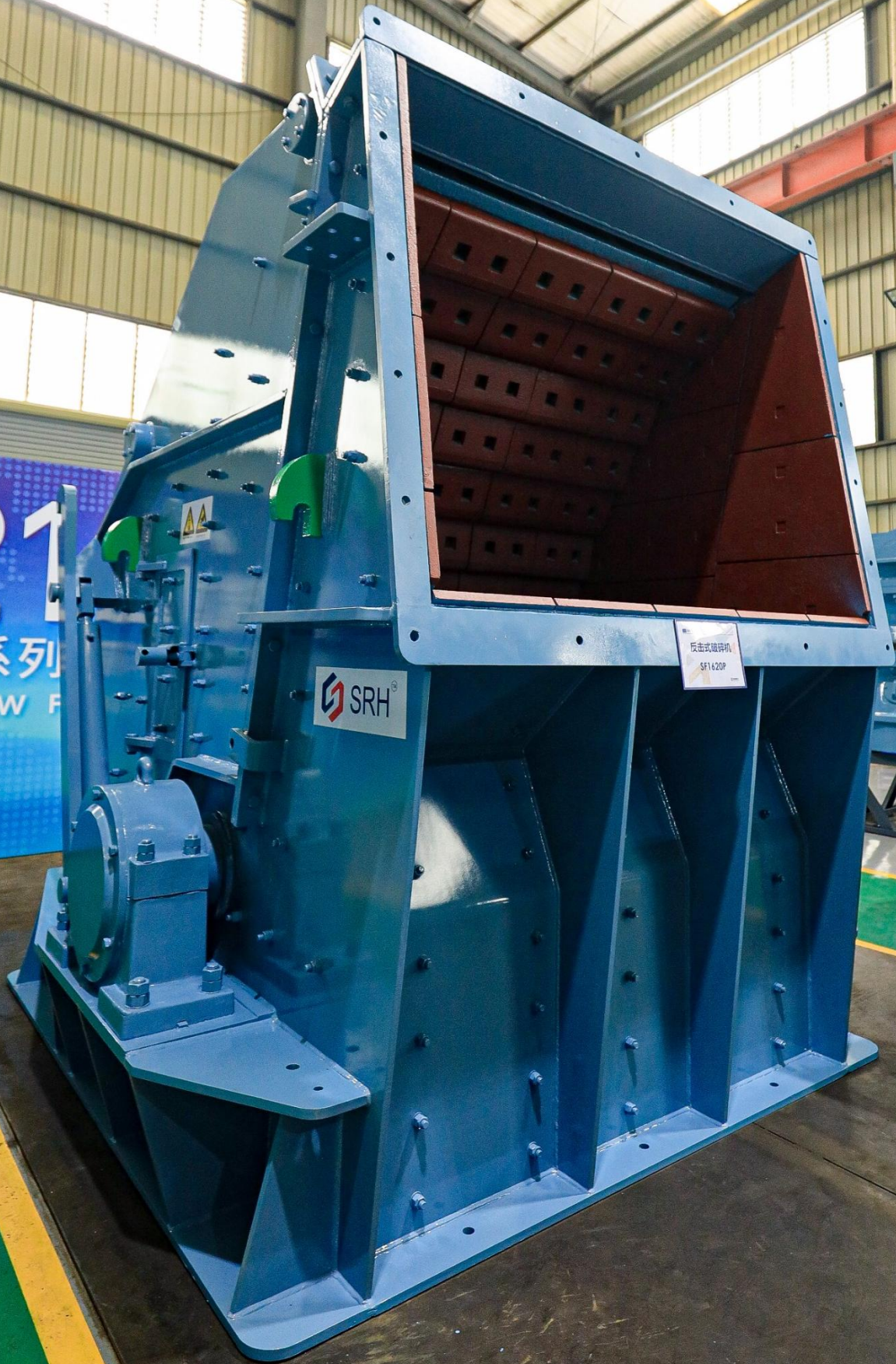

反击式破碎机
SF1420P

