

SV10D R500

VERTICAL SHAFT IMPACTOR

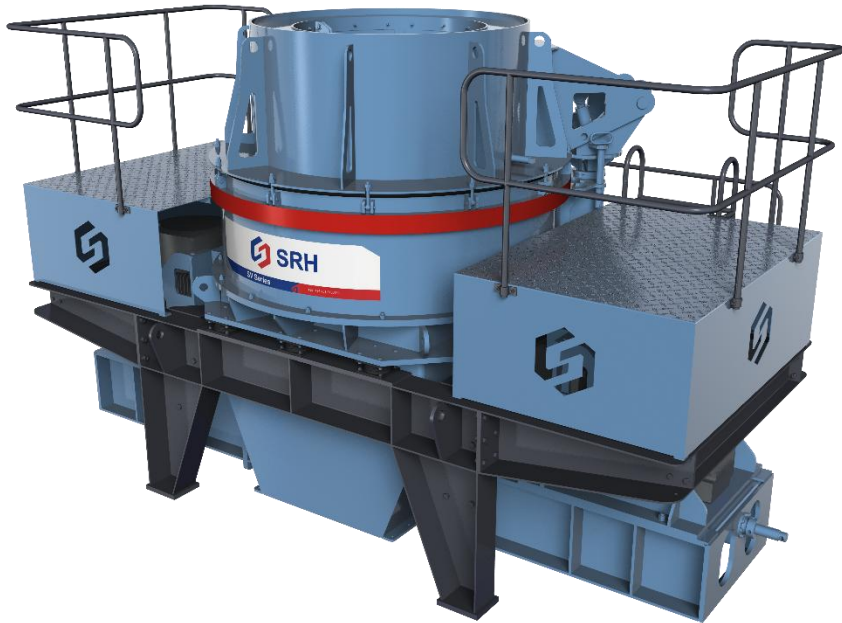

TECHNICAL DETAILS

Model	SV10D R500 Base Unit
Capacity	305-500tph
Max feed size	40mm
Installed power	2 250kW
Tip Speed m/s	45-75
Max lift	3850kg

DIMENSIONS

Weight	18549kgs approx.
Length	5647mm
Width	3207mm
Height	3061mm

Note- Weight includes basic crusher, starting Cabinet, rotor balancing device, tools, motors, v-belts for drives





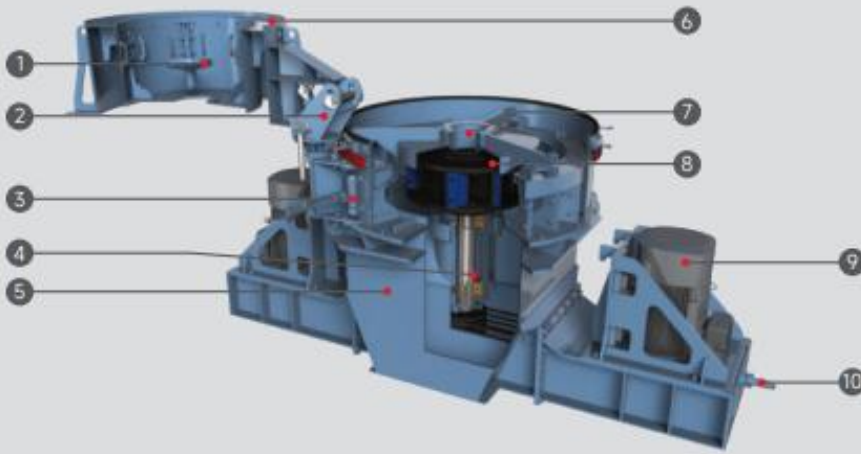

- 1 SPREADER PLATE
- 2 ROOF LIFTER
- 3 DOOR
- 4 SHAFT LINE ASSEMBLY
- 5 CRUSHER BASE
- 6 HOPPER
- 7 FEED TUBE
- 8 ROTOR
- 9 MOTOR
- 10 ADJUSTMENT ROD

Overall Dimensions

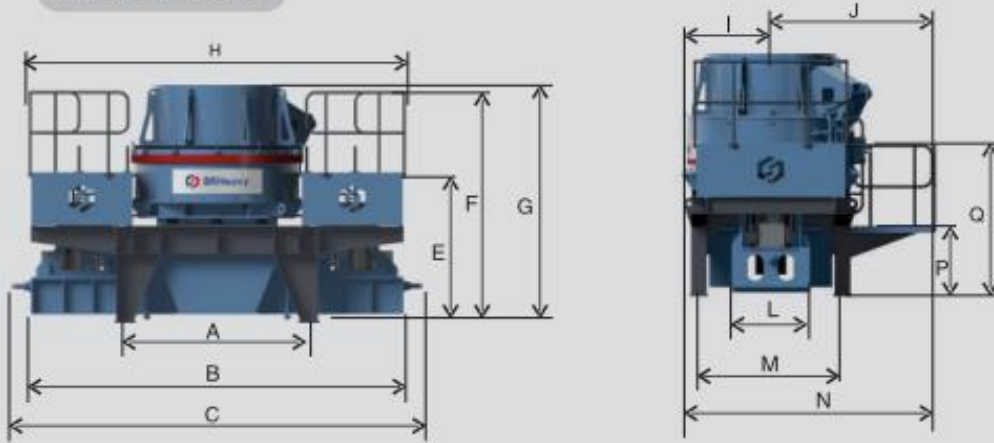

A	2340
B	5088
C	5647
E	1883
F	2901
G	2964
H	5142
I	2310
J	2052
L	1040
M	1838
N	3207
P	973
Q	1973

Product Gradation Curve

